

North America

Veeder-Root
125 Powder Forest Drive
Simsbury, CT
800-323-1799

Asia Pacific

Veeder-Root Singapore
246 MacPherson Road
#08-01 Betime Building
Singapore 348578
Tel: +65 6745-9265
Fax: +65 6746-1791

Europe

Veeder-Root EMEA
Hydrex House
Garden Road
Richmond, TW9 4NR
UK
Tel: +44 (0) 20 8392 1355
Fax: +44 (0) 20 8878 6642

Australia

Veeder-Root Australia
20 Highgate Street
Auburn, NSW 2144
P.O. Box 6804
Silverwater NSW 2128
Australia
Tel: +61 2 8737 7777
Fax: +61 2 97379332

Latin America

Veeder-Root
125 Powder Forest Drive
Simsbury, CT
800-323-1799

China

Veeder-Root Beijing
Room 2202, SCITEC Tower,
22, Jianguomen Wai Sajie
Beijing 100004, China
Tel: +86 10 6512-8081
Fax: +86 10 6522-0887

For information on systems design and product specifications in North America, call:

800-323-1799

For international sales and support, please contact your local sales office.

Red Jacket offers sales and applications support virtually anywhere in the world. We're committed to helping you improve your fueling profitability by developing new fuel delivery technologies that maximize fuel flow and deliver the best total cost of ownership. Please contact us at the closest location listed above, or visit us at www.redjacket.com.

North America for inside sales call

1-888-561-7942

Products and Solutions that Optimize Fuel Flow and Profits





Red Jacket has the resources that help customers with flow requirements, and site optimization. We take a comprehensive approach to product design that delivers the fuel flow you need, and also factors in important cost considerations such as the equipment's serviceability, safety, ease of upgrades, and impact on environmental compliance.

Reliable Products and Resources to Help Sites Reach Peak Performance

Site & Flow Planning

At Red Jacket we focus on three keys to fueling profitability.

- Providing the information you need to choose a solution for your specific site.
- Helping you ensure environmental compliance and fueling system uptime.
- Reducing your total cost of ownership to maximize your fueling profit potential.

Flow Planning Improves Site Performance

Improved flow isn't just about the size of your pumps. Understanding how your site works, and the impact of other equipment on flow rates, can help you make the right equipment choices.

You want to work with a company who understands the entire site, and recognizes that product performance in the test lab has little bearing on real-life results. A company with a full range of products to control flow and reach maximum output limits at the pump so you know that the solutions they recommend fit your business needs, not theirs. That company is Veeder-Root/Red Jacket, your Flow Resource.

Red Jacket's Flow Optimization Software Guide

Planning flow patterns at a site is an important step towards top performance. Veeder-Root has developed a comprehensive software guide that takes you through the variables of a fueling site. Intuitive and easy-to-use, Red Jacket Flow Optimization Software uses information and equipment specs to identify the correct STP model to optimize flow.

Knowledgeable Support is Only a Phone Call Away

If your site has unique characteristics or equipment configurations that our Flow Optimization Software doesn't support, or that require specialized knowledge, our application personnel on the Red Jacket Flow Hotline are available to help. Contact them at our 800# in the U.S., or call your local Veeder-Root office.

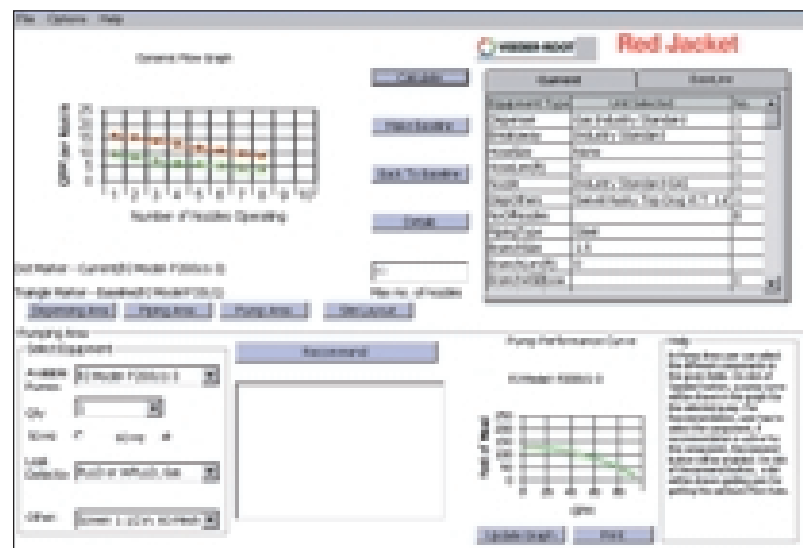

Red Jacket Flow Optimization Software.

Consistent Flow That Meets Everyone's Standards

Managing Flow Control

Flow control systems include controllers, demand based staging, and flow-limiting technologies that optimize fuel flow rates while meeting maximum flow rate regulations. Flow control increases fuel throughput and profitability by providing consistent maximum flow at all nozzles. Bottom line, your site can deliver all of the fuel your customers demand, maximizing turns and traffic to squeeze every drop out of fueling profits.

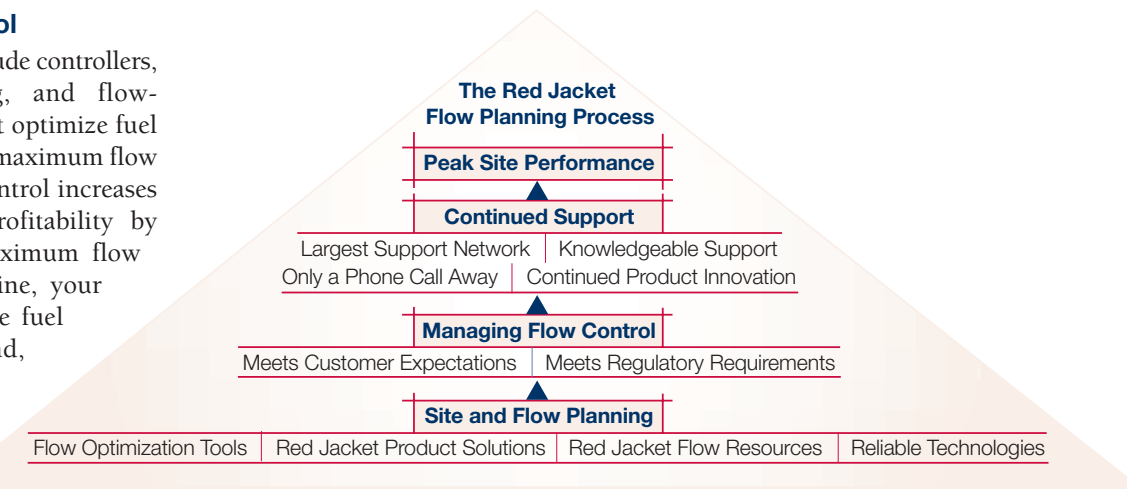

Flow Control Comparison

	RJ 2HP Variable Speed	RJ 2HP Fixed Speed
Flow Rate*		
Maximum Flow Rate	95 GPM	91 GPM
Manifolded System Max Flow Rate	172 GPM	168 GPM
Optimum Nozzle Flow Rate**	Varies by Nozzle	Optimized for all Nozzles
10 GPM Flow Control		
Requires a Flow Limitation at the Nozzle***	Possible	Yes
Dispenser Flow Control ⁽¹⁾	Best	Best
Mechanical Flow Limiter ⁽²⁾	Option	Option
Total Cost of Ownership		
Equipment Purchase Cost	Higher	Lower
Installation Cost	Higher	Lower
Maintenance Costs	Higher	Lower
Power Efficiency	Equal	Equal
Power Use at Max Flow Rate****	2598 watts	2587 watts

* As measured in third party tests at STP discharge head.

** Variable speed pumps may not optimize flow rates at every fueling location because flow rates are calibrated only at the first nozzle.

*** Variable speed pumps calibrated at one nozzle may not meet the 10 GPM maximum flow rate requirement at all nozzles.

**** As measured in third party tests.

(1) What is Dispenser Flow Control?

Dispenser Flow Control systems measure and adjust flow rates at each individual nozzle. Dispenser-based flow control systems can be used with either fixed or variable speed submersible pumps.

(2) What is a Mechanical Flow Limiter?

A Mechanical Flow Limiter is a device placed on the line to limit flow to each individual dispenser.

High Volume Site Considerations

High volume sites pose special opportunities for improved flow rates. These sites require faster fueling cycles and more customer turns in order to maximize return on the significant site investment.

Pump upgrades:

Upgrading the size (HP rating) of your pumps can have a substantial benefit at high volume sites. A simple upgrade from a 1 1/2 HP to a 2 HP pump can increase flow by over 22% when 8 nozzles are operating. Over the course of a 3-hour peak period that can translate to an additional 381 gallons of fuel pumped.

Manifolded systems:

Manifolding two or more pumps together provides redundancy and system uptime even if one pump requires service, as well as the ability to achieve higher flow rates when a large number of nozzles are open at the same time.

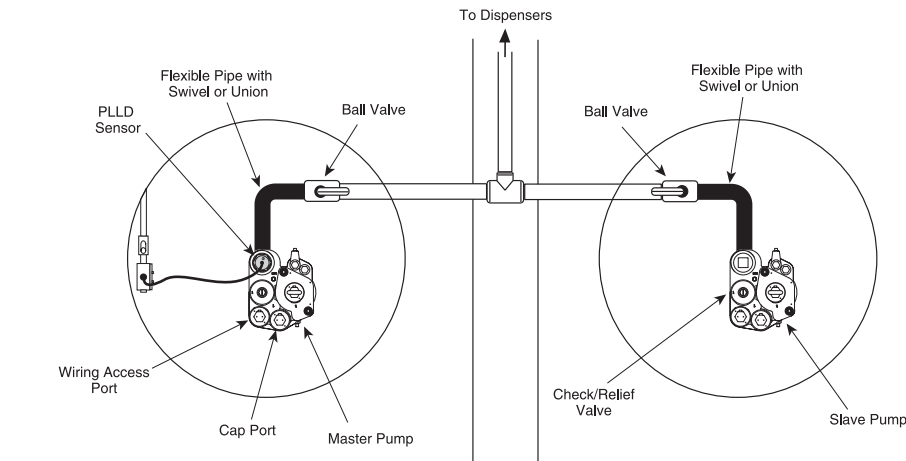

Manifolded systems provide higher flow rates and improved uptime.

Another benefit of manifolded systems is superior inventory management. At sites using product blending, a manifolded system will ensure that all three products keep flowing, even if one pump fails. During “fueling rush hours”

siphon systems often can't transfer fuel fast enough to avoid product run-out. A manifolded system will overcome this problem and ensure that product is available throughout peak fueling periods.

Submersible Turbine Pumps Designed to Meet Your Needs

Red Jacket Makes Sense

For over 40 years the name Red Jacket has become synonymous in the petroleum industry with a range of high-quality, high-performance products. Red Jacket has the largest installed base of submersible pumps in the industry.

Fixed Speed Pumps

Fixed speed pump control is a simple technology, with a history of reliable performance and system uptime.

Fixed speed pump control is cost effective. The initial cost of fixed speed

equipment is lower than variable speed options, as is the total cost of ownership.

Variable Speed Pumps

Variable speed pumps are designed to measure demand and control the speed of the pump, allowing it to spin faster as demand requires. Variable speed pumps allow for the use of higher horsepower (HP) pumps to meet peak demand without exceeding regulated maximum flow rates.

Whichever Red Jacket STP technology you choose, our sales and service organization will be there to support you, anywhere in the world.

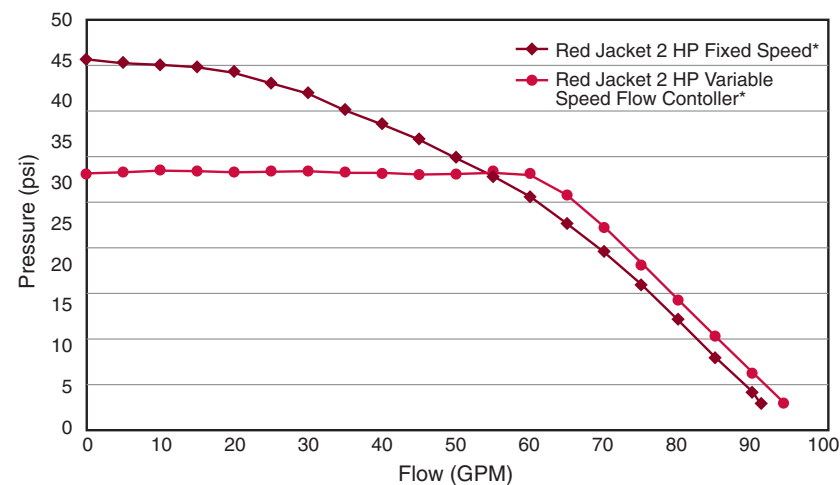

* As measured in third party tests at STP discharge head.

Submersible Turbine Pumps



The Red Jacket Submersible Turbine Pump

Advanced environmental protection, serviceability, safety and flow

Performance Benefits

- Available fixed and variable speed
- Lowest pressure drop across the packer manifold optimizes flow with any sized motor.

Environmental Benefits

- Service spill elimination
 - Check valve design
 - Spill-free extractable
- Prevents false alarms and downtime
 - Vacuum Sensor Siphon System
- Environmental compliance without fuel flow restrictions
 - Integrates with V-R PLLD systems

- Wide range of fuel compatibility
 - Diesel; 100% gasoline; 80% gasoline with 20% TAME, ETBE, or MTBE; 0-100% Ethanol; 0-100% Methanol

Service and installation benefits

- Quick, simple and safe yoke assembly
- Easy to service and install extractable
- Manifold design flexibility for vertical or horizontal discharge
- Built-in contractor's box eliminates need for yoke adjustments



Maxxum Big Flo

Maximum serviceability, safety and performance

Performance

- Highest flow rate of any 6" fixed speed STP
- Redesigned flow path reduces flow restrictions

Environmental

- Compatible with Veeder-Root PLLD
- Vapor recovery pump driving port
- Transducer port for electronic leak detection

Service and installation benefits

- Easy and safe electrical yoke disconnect
- Easy termination of pump wiring in conduit box
- Quick removal of extracta pump head
- Quick accessibility of check valve

Red Jacket is Your Flow Resource for Alternative Fuels

Red Jacket is prepared to help our customers meet local or regional requirements for reduced air emissions, or your company's desire to utilize alternative fuels. Our AG pump product lines are designed to handle E-85 fuel formulations and can handle alcohol concentrations of up to 100%

If you're looking for a safe, efficient system for pumping LPG we offer the best LPG pump in the industry. Contact us for more information on our flow solutions for alternative fuels.

Red Jacket Premiere LPG Submersible Pump

The high performance pump for a cleaner environment

Performance

- High differential pressure capability for guaranteed flow performance with various LPG mixtures
- Certified design explosion-proof submersible electric motor
- Multi-stage centrifugal pumping system for reduced power consumption

Service and installation benefits

- Bearing Cooling and Lubrication System for longer life, lower maintenance
- Split pump/motor design for easy installation and maintenance



Made for Alternative Fuels

Controllers



Red Jacket Variable Speed Flow Controller

A better approach to variable speed pumping

Performance

- Flexible control when used in manifolded systems
- Accurate flow control in any site configuration using fuel line pressure
- More flow than competitive products when you need it most
- 45°C operating temperature

Service and installation benefits

- Designed to save installation costs when integrated with Veeder-Root 350 PLLD
- Doesn't require intrinsically safe wiring from control box to pump
- Meets FCC guidelines
- Measures and maintains line pressure
- Integrates seamlessly with V-R PLLD



IQ Control Box

Easy to use, easy to install control for manifolded pump systems

Performance

- Provides motor protection from dry run conditions
- Protects wiring and controls from locked rotor or high currents
- Monitors site power conditions to ensure uninterrupted fueling and long motor life

Service and installation benefits

- Single press and hold button for easy calibration
- Easy-to-use wiring terminal with familiar labeling
- Easily retrofitted to existing locations



Isotrol 1-8

The most versatile dispenser handle signal isolation system available today

Performance

- Isolates the handle signals between each dispenser
- Isolates and protects individual dispensers from wiring shorts or phasing issues
- Isolates and protects technicians from dangerous feedback during service

Service and installation benefits

- Dedicated Automatic Tank Gauge (ATG) line leak output and coil terminals are labeled for easy wiring and compatibility
- May be used with Red Jacket's Submersible Turbine Pump, Big Flo Pump or IQ Control Box, or as a "stand alone" with on-board 30-amp power relay
- Easily retrofitted to existing locations

Accessories



Veeder-Root PLLD Pressurized Line Leak Detection System

Protect your investment while maximizing fuel sales

Performance

- Increased flow rate saves you money*
- .5 GPM per nozzle higher flow rate vs. MLLD
- 2 GPM per nozzle higher flow rate vs. ELLD

Service and installation benefits

- Eliminates the recurring cost of replacement of MLLD
- Eliminates the need for annual line testing
- Eliminates the need for annual mechanical test

** Site with 11 fueling locations with 2 HP pump*



FXV System-Mechanical Leak Detection and Testing

The fastest line leak test available for hourly monitoring

Performance

- Guaranteed to detect at a rate of 3 gph at 10 psi for 24 months from date of manufacture
- Fast test times enable the FXV to operate effectively in areas that experience extreme temperature changes
- Handles a variety of fuels including diesel

Service and installation benefits

- Adapts to applications using high-resiliency lines, such as flexible piping
- Installs and troubleshoots easily No special wrenches or tools

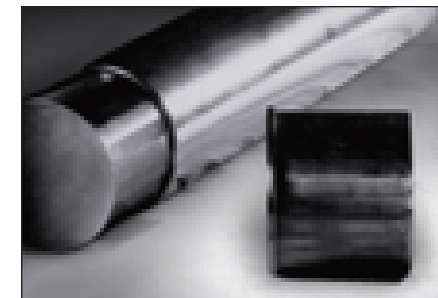

Trapper™

Your savings begin when the Trapper goes in

Performance

- Specially designed screen blocks tank particulates from entering the fluid system, prolonging filter life
- Continuous slot design prevents accumulation and lodging of particles present in underground tanks, maintaining peak pumping performance

Service and installation benefits

- Reduces filter changes to as low as once per year per line, saving on labor and filter costs
- Reduces product spills and the potential for liability by reducing the number of filter changes
- Self-cleaning, non-clog design dramatically reduces maintenance costs



Veeder-Root has developed Flow Optimization Software to help guide you in choosing the best equipment to optimize flow at your retail petroleum site. Contact the Flow Resource to order your copy, or for more information on systems design or product specifications.

The Flow Resource 800-323-1799