

# ISOTROL™ 1-8 CONTROL BOX

## INSTALLATION AND OWNER'S MANUAL

# Red Jacket

## INTRODUCTION

RED JACKET'S ISOTROL™ 1-8 control box with dispenser isolation is a simple method to maximize dispenser servicing safety and eliminate feedback in dispenser circuits. Up to eight dispenser handle signals for the same product can be connected to this control box with complete channel to channel isolation as well as dispenser to submersible turbine pump isolation. If equipped with the contactor, this device also serves as the relay control box for the submersible pump.

### DANGER

This device is intended to provide electrical isolation between the dispenser pump enable (Hook) signal and the submersible turbine pump control relay. Other energized sources of power can still exist within the dispenser even with this device installed. Verify that all sources of power are disconnected before servicing dispenser.

## BEFORE INSTALLATION

The following defined terms are used throughout this instruction manual to indicate the presence of hazards and identify important information concerning the proper use of the product.

### DANGER

Indicates the presence of a hazard that will cause severe personal injury, death, or substantial property damage if ignored.

### WARNING

Indicates the presence of a hazard that can cause severe personal injury, death, or substantial property damage if ignored.

### NOTICE

Indicates special instructions on installation, operation, or maintenance that are important but not related to personal injury hazards.

Carefully read this entire manual along with all applicable local codes. Follow the guidelines stated in NFPA 30, 30A and 70 from the National Electric Code to safeguard the installation and operation of this equipment as well as the entire system. Failure to follow these instructions may result in personal injury, death, or severe property damage.

Retain this instruction manual with the equipment after installation for future use.

## MODEL INFORMATION

Model No.	Device Description	Red Jacket Part No.
Isotrol 1-8R	120V w/Relay	880-047-1
Isotrol 1-8	120V w/o Relay	880-049-1
Isotrol 1-8R-i	240V w/Relay	880-048-1
Isotrol 1-8-i	240V w/o Relay	880-050-1

### NOTICE

The voltage in the device description above identifies the circuit board power, dispenser input signal levels, and the coil rating for the optional relay. Control boxes with relays installed have contacts rated DPST 30A, 240V, 50/60 Hz. Refer to Figure 1 for correct electrical connections to the control box.

# INSTALLATION AND WIRING INSTRUCTIONS

**WARNING** This equipment must be installed in a non-hazardous location.

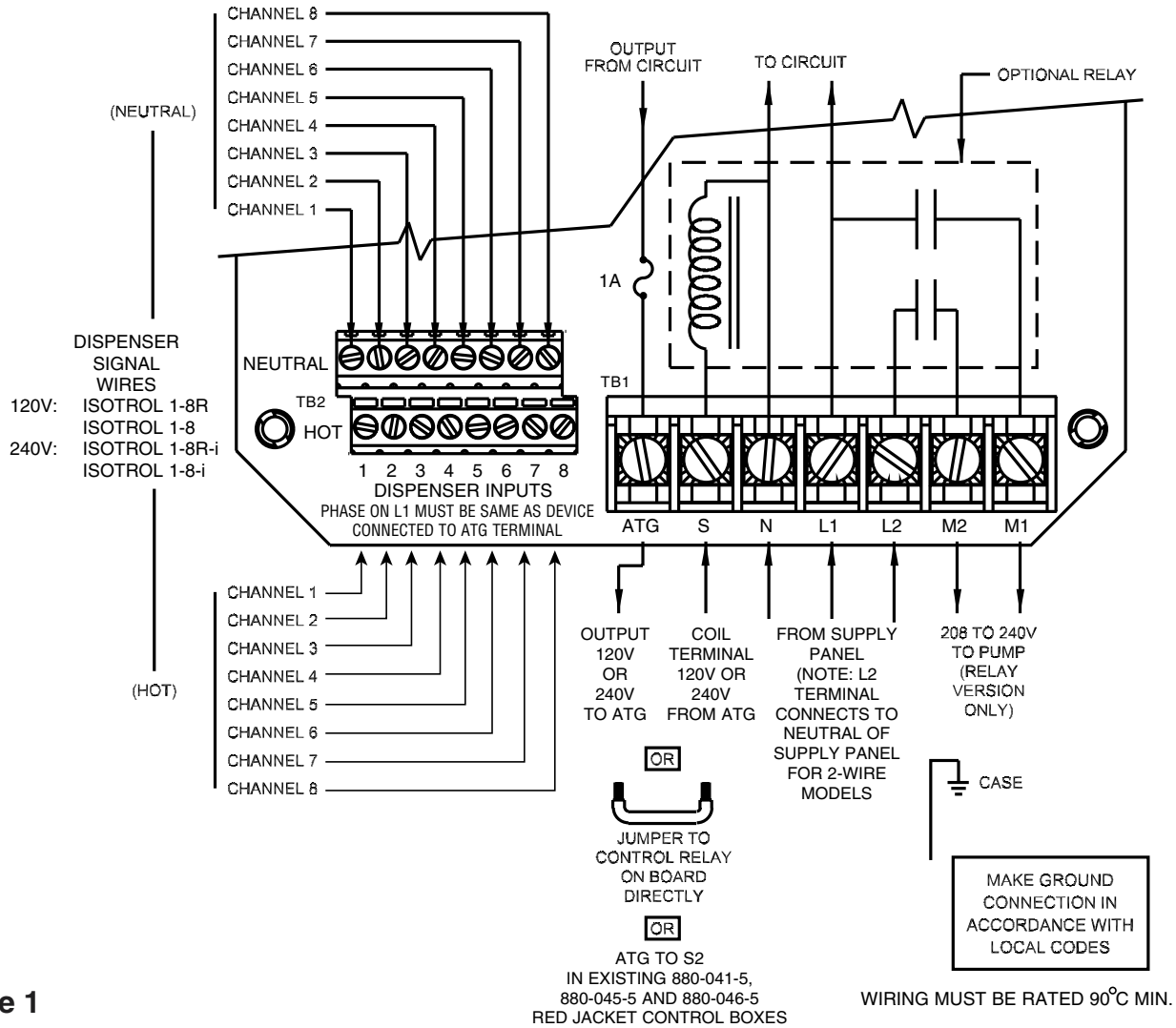

Figure 1

**NOTICE** This device is not compatible with the Red Jacket Control Box 880-042-5. Consider replacing 880-042-5 in an existing location with ISOTROL 1-8-i that has the on board relay. Compatibility of this device with Control Box Models 880-041-5, 880-045-5 and 880-046-5 assumes that they have been installed and wired according to their diagrams.

1. Locate an area that allows all wiring to enter through the bottom knockouts of the control box. Consider the ability to view the indicator on the side of the base when choosing a location.
2. Remove the cover of enclosure and mount the base.

## DANGER

Always lock or tag out the supply power before attempting to connect to the dispenser isolation control box. Use a voltmeter to verify the presence of voltages.

3. Use Figure 1 above or the diagram on the inside of the enclosure lid to connect input power to the L1, L2, and N terminals of TB1 (10 to 18 AWG). A connection to the L2 terminal is only necessary on units that have relay. For multiple box installations refer to Figure 2.

## DANGER

The neutral connection from the service panel to the N terminal of TB1 must be a **permanently connected, unswitched connection**.

## NOTICE

If S terminal and L1 terminal are sourced from different breakers at supply panel size neutral wire accordingly TB1 will accept up to 10 AWG wire.

4. Locate the grounding screw on the enclosure base and attach a ground wire to this point.
5. Motor leads M1 and M2 should be terminated to the M1 and M2 terminals on TB1 if applicable.
6. For installations that have tank gauging equipment the circuit will energize the ATG terminal of TB1 when a dispenser signal is detected. The ATG terminal will be the **same voltage and phase as the power supplied to the L1 terminal**.

## NOTICE

It may be necessary that the phase of L1 (TB1) match the phase of the power supplying the ATG device in order to prevent cross phasing which may damage the input on some ATG equipment.

7. The return wire from the ATG device should be connected to the S terminal on TB1. The S terminal is the coil of the relay with the other side of the coil terminated to the N terminal on the circuit board. The coil rating of the relay is 4 VA at 120V or 240V, depending on model.

**For installations with the pump control relay in a different enclosure utilize the ATG terminal of TB1 to energize the coil. This output is rated 1A at 250V and fuse protected for these applications. See Figure 3**

**For installations without external control connections a short jumper wire (minimum 18 AWG) must be placed between ATG and S terminals of TB1 so that the dispenser isolation circuit can energize the relay on circuit board.**

8. Terminate up to eight dispenser signals for the same petroleum product to TB2. Each dispenser should have its own hot and neutral leads terminated as shown on the diagram. TB2 can accept 14-28 AWG wire.
9. After all dispenser signal leads have been connected to TB2 replace the lid on the enclosure.

**At this time the control box with dispenser isolation can be energized. The neon indicator on the side of the enclosure will illuminate once the device is powered. A simple test to verify functionality is to operate all dispenser handles that are tied to the box and check the output for energizing.**

MULTIPLE ISOTROL CONTROL BOX  
WIRING DIAGRAM

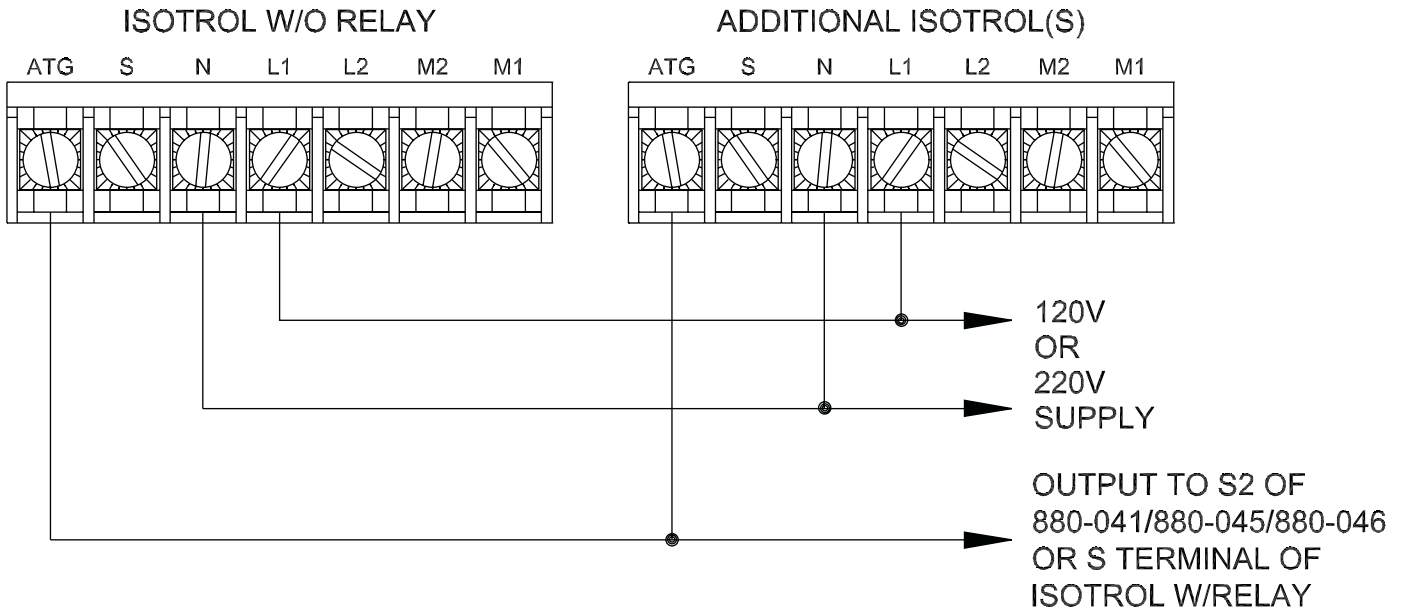

Figure 2

SUGGESTED WIRING TO EXISTING RED JACKET CONTROL BOX

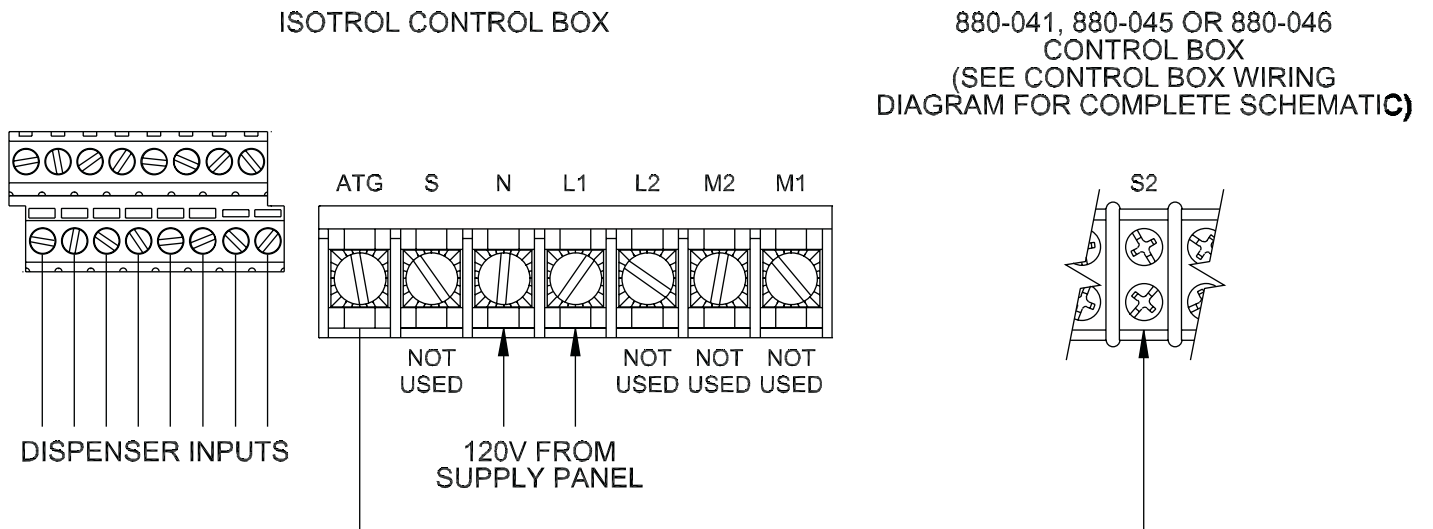
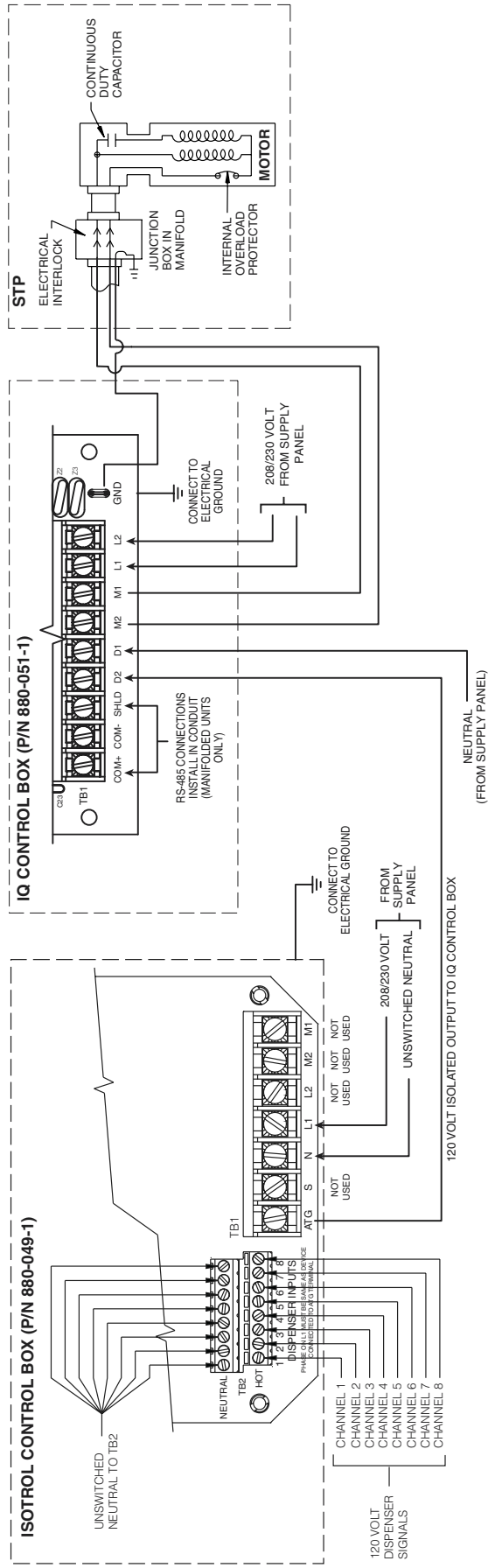

Figure 3



The following terms are used in this document to bring attention to the presence of hazards of various risk levels, or to important information concerning use of the product.

- Danger!** Indicates the presence of a hazard that **will** cause **severe** personal injury, death, or substantial property damage **if ignored**.
- Caution** Indicates the presence of a hazard that **will** or **can** cause **minor** personal injury or property damage **if ignored**.
- Notice** Indicates special instructions on installation, operation, or maintenance that are important but not related to personal injury hazards.

#### ISOTROL CONTROL BOX WIRING PRECAUTIONS

**Danger!** This device is intended to provide electrical isolation between the dispenser pump enable (Hook) signal and the submersible turbine pump (STP) control relay. Other energized sources of power can still exist within the dispenser even with this device.

**Danger!** The neutral connection to the N terminal of TB1 and N terminal of TB2 must be from the service panel and be a permanently connected, unswitched connection.

The N connection on TB1 and the eight N connections on TB2 may be spliced to a common neutral wire from the service panel described above.

Make only one "wire" connection on each N terminal on TB2.

**Caution** The phase of L1 (TB1) must match the phase of the power supplying the ATG device in order to prevent cross phasing which may damage the input on some ATG equipment.

#### GENERAL WIRING PRECAUTIONS

Wiring must be rated 90 °C minimum.

Make ground connection in accordance with local codes.

FIGURE 4: ISOTROL TO IQ SYSTEM WIRING - 120 VOLT DISPENSER SIGNALS

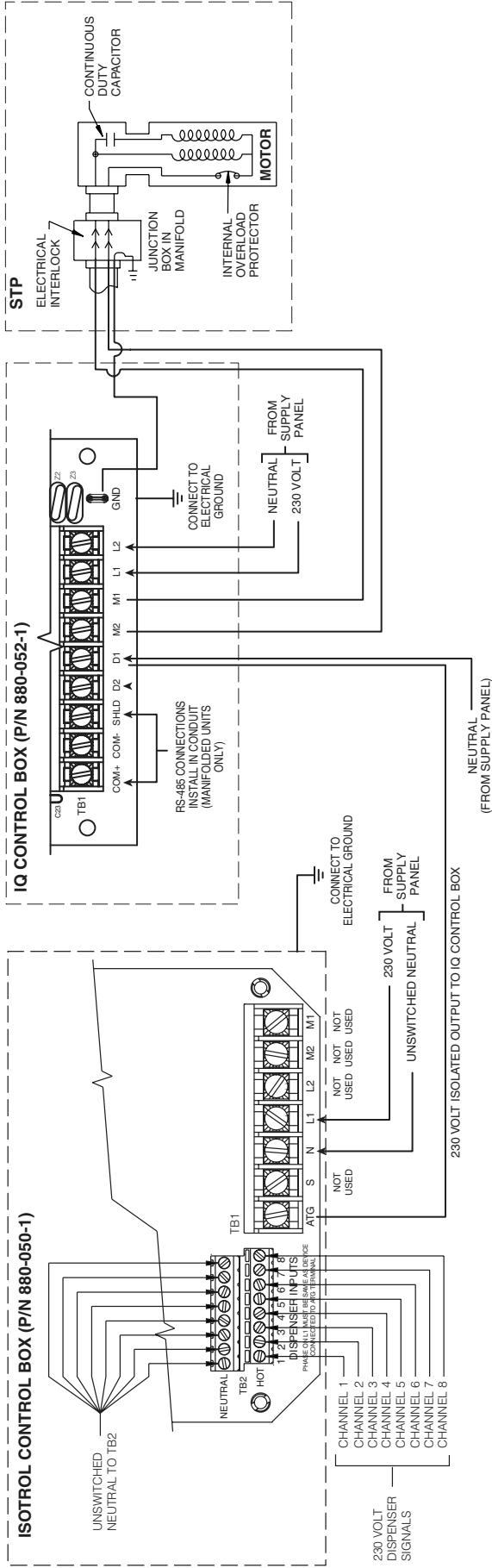

The following terms are used in this document to bring attention to the presence of hazards of various risk levels, or to important information concerning use of the product.

**Danger!** Indicates the presence of a hazard that **will** cause **severe** personal injury, death, or substantial property damage **if ignored**.

**Caution** Indicates the presence of a hazard that **will** or **can** cause **minor** personal injury or property damage **if ignored**.

**Notice** Indicates special instructions on installation, operation, or maintenance that are important but not related to personal injury hazards.

#### ISOTROL CONTROL BOX WIRING PRECAUTIONS

**Danger!** This device is intended to provide electrical isolation between the dispenser pump enable (Hook) signal and the submersible turbine pump (STP) control relay. Other energized sources of power can still exist within the dispenser even with this device.

**Danger!** The neutral connection to the N terminal of TB1 and N terminal of TB2 must be from the service panel and be a permanently connected, unswitched connection.

The N connection on TB1 and the eight N connections on TB2 may be spliced to a common neutral wire from the service panel described above.

Make only one "wire" connection on each N terminal on TB2.

**Caution** The phase of L1 (TB1) must match the phase of the power supplying the ATG device in order to prevent cross phasing which may damage the input on some ATG equipment.

#### GENERAL WIRING PRECAUTIONS

Wiring must be rated 90°C minimum.

Make ground connection in accordance with local codes.

FIGURE 5: ISOTROL TO IQ SYSTEM WIRING - 230 VOLT DISPENSER SIGNALS

## TROUBLESHOOTING GUIDE

### WARNING

At any time the enclosure must be opened during a troubleshooting procedure, disconnect controller power prior to removal of the cover. This includes the dispenser signal outputs that are powered from separate circuits in the system.

<b>CONDITION</b>	<b>CAUSE/SOLUTION</b>
Relay won't energize	Verify circuit power on and indicator illuminated Verify dispenser is signaling control box Verify all wiring connections Verify ATG terminal is energized Replace fuse F1 with 1A type TR1 style Replace relay
ATG won't respond	Verify ATG terminal is energized Verify phase of ATG and control box power Replace fuse F1 with 1A type TR1 style
Relay always energized	Verify dispenser signals are de-energizing . Check all wiring connections at TB1 and TB2.
Residual voltage on de-energized input	Verify isolation by removing dispenser input lead and measuring voltage at that input when a different input channel is energized

Contact Red Jacket Technical Support for additional troubleshooting information at 1-800-777-2480.

# Red Jacket

By  VEEDER-ROOT

125 Powder Forest Drive • Simsbury, CT 06070  
Tel: (860) 651-2700 • Fax: (860) 651-2719